



PORTABLE AIR CON/DEHUMIDIFIER/COOLER/ HEATER WITH WINDOW KIT

MODEL NO: **SAC16000**

Thank you for purchasing a Sealey product. Manufactured to a high standard, this product will, if used according to these instructions, and properly maintained, give you years of trouble free performance.

IMPORTANT: PLEASE READ THESE INSTRUCTIONS CAREFULLY. NOTE THE SAFE OPERATIONAL REQUIREMENTS, WARNINGS & CAUTIONS. USE THE PRODUCT CORRECTLY AND WITH CARE FOR THE PURPOSE FOR WHICH IT IS INTENDED. FAILURE TO DO SO MAY CAUSE DAMAGE AND/OR PERSONAL INJURY AND WILL INVALIDATE THE WARRANTY. KEEP THESE INSTRUCTIONS SAFE FOR FUTURE USE.



Refer to
instruction



Do not cover



Indoor use only



Caution:
Risk of fire

This unit uses a flammable refrigerant.

If refrigerant leaks and comes in contact with fire or heating part, it will create harmful gas and there is risk of fire.

Read the **USER MANUAL** carefully before operation.

1. SAFETY

1.1. ELECTRICAL SAFETY

- WARNING!** It is the user's responsibility to check the following:
 - ✓ Check all electrical equipment and appliances to ensure that they are safe before using. Inspect power supply leads, plugs and all electrical connections for wear and damage. Sealey recommend that an RCD (Residual Current Device) is used with all electrical products.
 - Electrical safety information.** It is important that the following information is read and understood:
 - ✓ Ensure that the insulation on all cables and on the appliance is safe before connecting it to the power supply.
 - ✓ Regularly inspect power supply cables and plugs for wear or damage and check all connections to ensure that they are secure.
 - Important:** Ensure that the voltage rating on the appliance suits the power supply to be used and that the plug is fitted with the correct fuse.
 - ✗ **DO NOT** pull or carry the appliance by the power cable.
 - ✗ **DO NOT** pull the plug from the socket by the cable.
 - ✗ **DO NOT** use worn or damaged cables, plugs or connectors. Ensure that any faulty item is repaired or is replaced immediately by a qualified electrician.
- If the cable or plug is damaged during use, switch off the electricity supply and remove from use.
- Ensure that repairs are carried out by a qualified electrician.**
- ✓ If the supply cord is damaged, it must be replaced by the manufacturer, its service agent or similarly qualified persons in order to avoid a hazard.
- CAUTION:** In order to avoid a hazard due to inadvertent resetting of the thermal cut-out, this appliance must not be supplied through an external switching device, such a timer, or connected to a circuit that is regularly switched on and off by the utility.

1.2. GENERAL SAFETY

- ✓ Check that the unit is in sound condition and good working order. Take immediate action to repair or replace damaged parts.
- NOTE:** this appliance is for professional repair only.
- ✓ Use recommended parts only. Unauthorised parts may be dangerous and will invalidate the warranty.
- NOTE:** Appliance is filled with R290.
- ✓ Appliance shall be installed, operated and stored in a room with a floor area larger than 12m².
- ✗ **DO NOT** perforate any of the components in the refrigerant circuit. Refrigerant gas may be odourless.
- ✗ **DO NOT** attempt any repairs / maintenance unless suitably qualified.
- ✗ **DO NOT** stand or place any object closer than 500mm from the unit.
- ✗ **DO NOT** obstruct the air intakes or outlets of the unit, and **DO NOT** cover with washed clothes.
- ✗ **DO NOT** place any object into the outlets - the unit has a fan running at high speed, contact with this will cause injury.
- ✗ **DO NOT** operate the unit when you are tired or under the influence of alcohol, drugs or intoxicating medication.
- ✗ **DO NOT** switch the unit off by disconnecting it from the mains. ALWAYS switch to the "OFF" position first.
- ✗ **DO NOT** remove the float lever from the water collection tank.
- ✗ **DO NOT** connect or disconnect the plug from the mains with wet hands.
- ✓ Always discard the water from the collection tank, **DO NOT** use it for any other purpose.
- ✓ Place the unit on a level and stable surface.
- ✓ To prevent water from freezing, **DO NOT** use the unit at ambient temperatures below 0°C.
- ✗ **DO NOT** use the unit outside.
- ✗ **DO NOT** expose to rain, moisture or any other liquid.
- ✓ Ensure that heating appliances are not exposed to the flow of air from the unit.
- ✓ Before attempting to move the unit, empty the contents of the water tank. Use side carrying handles when moving unit.
- ✓ Switch off and disconnect unit from the mains before attempting any cleaning or other maintenance work.
- ✓ Ensure that the unit is turned off correctly when not in use, and stored in a safe, dry area, out of reach of children.
- ✓ Children from age 8 years and above, persons with reduced physical, sensory, or mental capabilities those with lack of experience and knowledge can use the appliance, if they have been given supervision or instruction concerning use of the appliance in a safe way to understand the hazards involved.
- ✗ **DO NOT** allow children to play with the appliance.
- ✗ **DO NOT** allow children to perform cleaning or user maintenance on the appliance without supervision.
- ✓ The appliance shall be disconnected from its power source during service and when replacing parts and, if that the removal of the plug is foreseen, it shall be clearly indicated that the removal of the plug has to be such that an operator can check from any of the points to which he has access that the plug remains removed.

- ✗ **DO NOT** immerse or expose the unit to rain, moisture or any other liquid.
- ✗ **DO NOT** leave the unit running unattended. Do not tilt or turn over the unit.
- ✗ **DO NOT** unplug while the unit is operating.
- ✓ The unit is designed only for use with R-290(propane) gas as the designated refrigerant.
- ✓ The refrigerant loop is sealed. Only a qualified technician should attempt to service.
- ✗ Do not discharge the refrigerant into the atmosphere.
- ✓ R-290 (propane) is flammable and heavier than air. It collects first in low areas but can be circulated by the fans.
- ✗ If propane gas is present or even suspected, **DO NOT** allow untrained personnel to attempt to find the cause.
- ✓ The propane gas used in the unit has no odor. The lack of smell does not indicate a lack of escaped gas.
- ✓ If a leak is detected, immediately evacuate all persons from the area, ventilate the room and contact the local fire department to advise them that a propane leak has occurred.
- ✗ **DO NOT** let any persons back into the room until the qualified service technician has arrived and that technician advises that it is safe to return to the room.
- ✗ No open flames, cigarettes or other possible sources of ignition should be used inside or in the vicinity of the units.
- ✓ Component parts are designed for propane and non-incentive and non-sparking. Component parts shall only be replaced with identical repair parts.
- ❑ **WARNING! FAILURE TO ABIDE BY THIS WARNING COULD RESULT IN AN EXPLOSION, DEATH, INJURY AND PROPERTY DAMAGE.**

2. INTRODUCTION

4-in1 high capacity, compact, portable air conditioner, air cooling with ventilation, dehumidifying and heating functions. Thermostatically controlled with built-in 24hr timer and sleep mode. Soft-touch control panel with LED digital display and remote control. Self-evaporating system reuses the moisture it collects from the air to help with the cooling process allows better efficiency, low maintenance and powerful cooling. Water-full indicator with auto-shut-off. Supplied with extendable exhaust ducting with window kits for extraction. Dehumidifying function capable of removing up to 50.4L/day and includes continuous drain hose. Eco-Friendly R290 refrigerant. Air conditioning temperature range 16-32°C. Washable filter. Auto-defrost function at low ambient temperature. The unit operates at temperatures as low as 5°C. Mounted on castor wheels for manoeuvrability.

3. SPECIFICATION

MODEL NO:	SAC16000
Cooling Capacity:	16000Btu/hr
Discharge Side Pressure:	3.2MPa
Electrical Class:	Class 1
Energy Rating:	A (EER: 2.6)
Fuse Rating:	16A
IP Rating:	IPX1
Mass of Refrigerant:	265g
Maximum Airflow:	450m ³ /hr
Maximum Exhaust Hose Length:	1.5m
Maximum Water Extraction Rate:	50.4L/day
Noise Level:	65dB(A)
Power Supply Cable Length:	1.8m
Power:	1712W (Cooling), 1300W (Heating)
Rated Capacity:	4700W (Cooling), 3280W (Heating)
Refrigerant:	R290
Suction Side Pressure:	0.7MPa
Supply:	230V ~ 50Hz

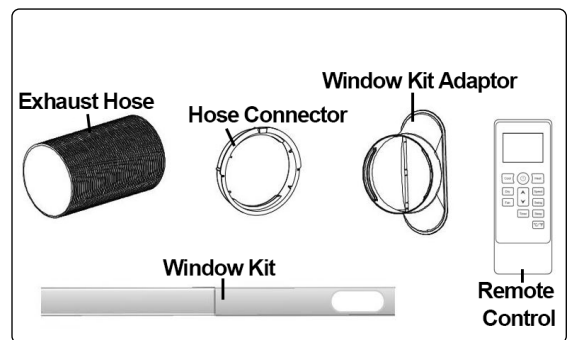
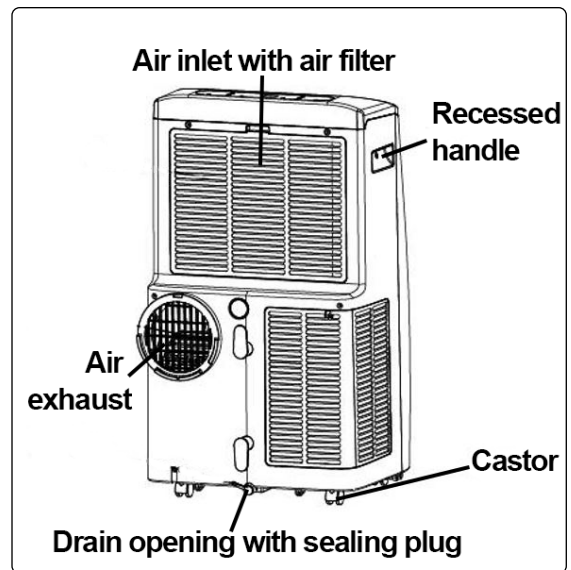
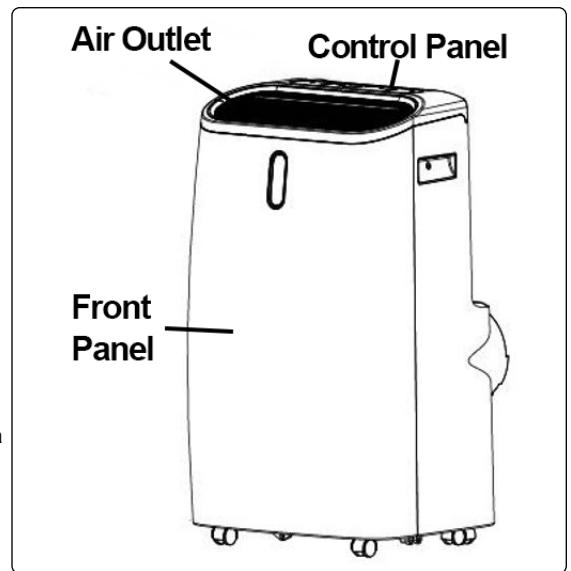

4. INSTALLATION

4.1. BEFORE INSTALLATION

Check the device for any damage or missing parts.

4.2. CHOOSE YOUR LOCATION

NOTE: If tipped more than 45°, allow the unit to set upright for at least 24 hours before start up.

4.2.1. Place the unit on a firm, level surface in an area with at least 50cm of free space around it to allow for proper air circulation.

× **DO NOT** operate in close proximity to walls, curtains, or other objects that may block air inlet and outlet. Keep the air inlet and outlet free of obstacles.

× **DO NOT** install the unit where it could be subject to:

- Heat sources such as radiators, heat registers, stoves or other products that produce heat.
- Direct sunlight
- Mechanical vibration or shock
- Excessive dust
- Lack of ventilation, such as cabinet or bookcase
- Uneven surface

□ **WARNING!** Install the unit in rooms which exceed 12m².

× **DO NOT** install the unit in a place where inflammable gas may leak.

4.3. ATTACH THE EXHAUST HOSE

The air conditioner must be vented outside to remove exhaust air from the room.

× **DO NOT** extend the exhaust hose which will result in decreased efficiency, even worse shut down the unit due to low back-pressure.

4.3.1. Adjusting the length of the flexible exhaust hose, and avoid bends in the hose. Then place AC near an electrical outlet.

4.3.2. Adjust the louver at the air outlet, and then switch on the unit.

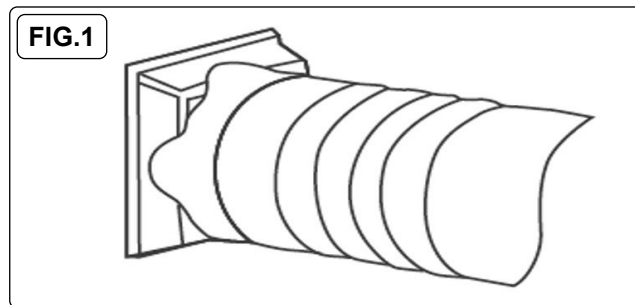

4.4.1. Connect the hose connector to one end of the exhaust hose (fig.1)

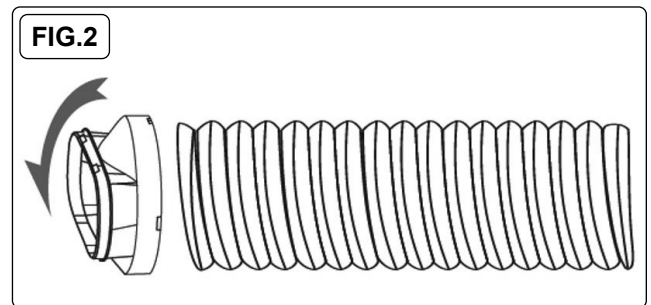

4.4.2. Connect the windows kit adapter to the other end of the exhaust hose (fig.2).

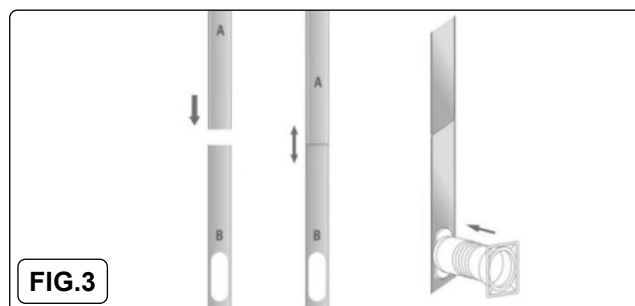

4.4.3. Extend the adjustable window kit to the length of your window. Connect the exhaust hose to the window kit (fig.3).

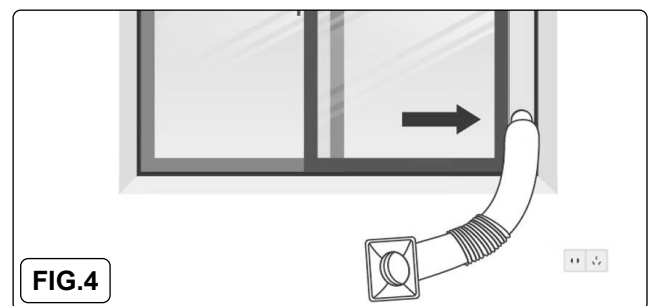

4.4.4. Close the window to secure the kit in place. Secure the window kit with duct tape if required (fig.4).

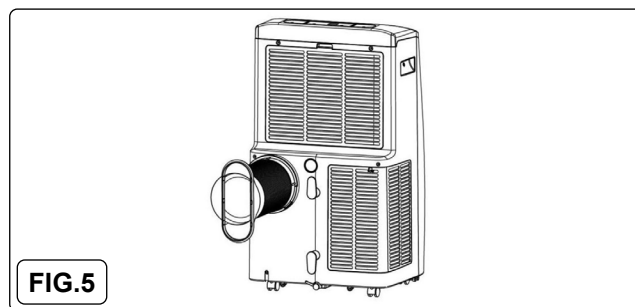

4.4.5. Attach the hose connector to the exhaust air outlet of unit (fig.5).

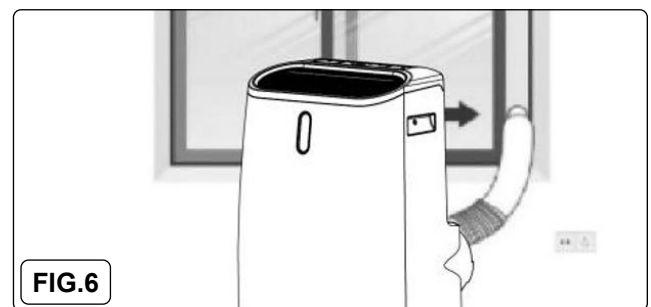

4.4.6. Avoid bends in the hose. Plug in to power supply. (fig.6).

5. OPERATION

5.1. CONTROL PANEL & DISPLAY

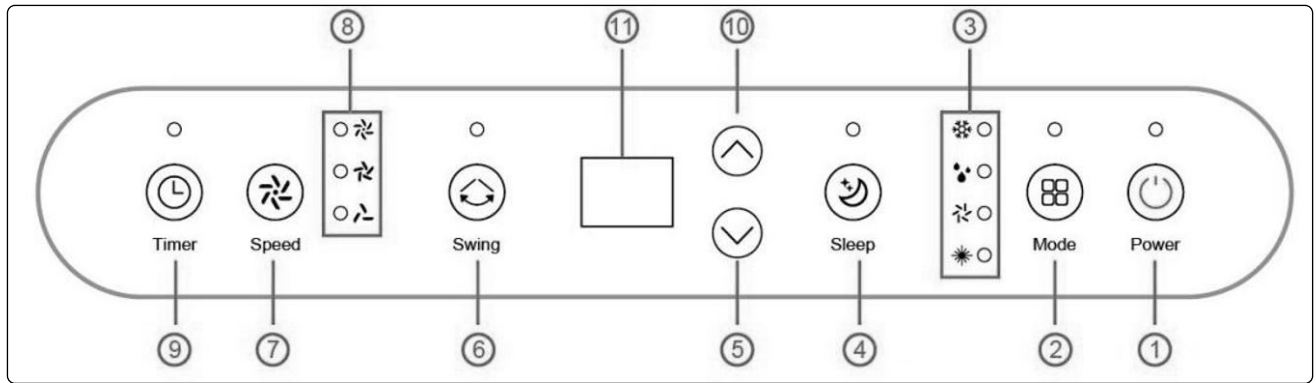

1	POWER	Press to switch the machine on or off.
2	MODE	Press to switch the operation mode between cool, dry, fan and heat.
3	MODE indicator	Indicates the MODE setting - cool, dry, fan and heat.
4	SLEEP	Press to turn sleep mode on or off.
5	DOWN	Decrease the desired temperature or timer settings.
6	SWING	Adjust the air flow direction vertically.

7	SPEED	Press to switch the fan speed from high, medium and low speed.
8	SPEED indicator	Indicates the SPEED setting - high, medium low.
9	TIMER	Sets a time for the unit to automatically start or stop.
10	UP	Increase the desired temperature (16-32°C)
11	DIGITAL DISPLAY	Displays timer setting and temperature.

NOTE: the above functions can also be performed on the remote control (fig.6).

5.2. START-UP & SHUTDOWN

- 5.2.1. Press POWER to turn the unit on. The unit runs in FAN as default.
- 5.2.2. Press MODE button to select the desired operation mode.
- 5.2.3. Press POWER again to turn off the power.

5.3. OPERATION MODES

The unit has five operation modes: Cool, dehumidify, fan, heat, sleep

5.4. COOLING

Select the cool mode to lower the temperature in your room.

- 5.4.1. Press MODE button repeatedly until the LED of COOL operation lights up.
- 5.4.2. Press Up/Down button to adjust the temperature which is displayed on the screen. The temperature can be set between 16°C and 32°C.
- 5.4.3. Press SPEED button repeatedly until the desired fan speed indicator lights up.
- 5.4.4. To control the direction of the air flow horizontally, press the SWING button on.

NOTE: The air conditioner stops if the room temperature is lower than selected temperature.

5.5. HEATING

- 5.5.1. Press MODE button repeatedly until the LED of HEAT operation lights up.
- 5.5.2. Press ADD/MINUS button to set the temperature higher than the room temperature. The fan speed can also be set.

5.6. VENTILATING

- 5.6.1. Press MODE button repeatedly until the LED of FAN operation lights up. In ventilation mode the room air is circulated, but not cooled.
- 5.6.2. Press SPEED button repeatedly to select the fan speed as desired.

5.7. DRYING/DEHUMIDIFYING YOUR ROOM

- 5.7.1. Press MODE button on the control panel or remote control, the LED of DRY operation lights up.
 - 5.7.2. The drainage hose should be attached to the unit for continuous operation.
- NOTE:** In this mode, the fan speed switches over to low speed and the temperature cannot be selected.

5.8. SLEEP MODE

The sleep mode can be activated when in cool mode and heat mode.

5.8.1. In cool mode:

After 1 hour the preset temperature is increased by 1°C, after another hour the preset temperature will again be increased by 1°C.

5.8.2. In heat mode:

After 1 hour the preset temperature is decreased by 1°C, after another hour the preset temperature will again be decreased by 1°C. The temperature is then kept constant for 10 hours and all indicators dim. The fan speed will switch over to low speed for silent operation, and cannot be selected.

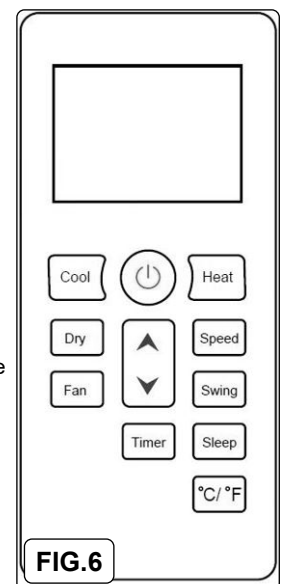
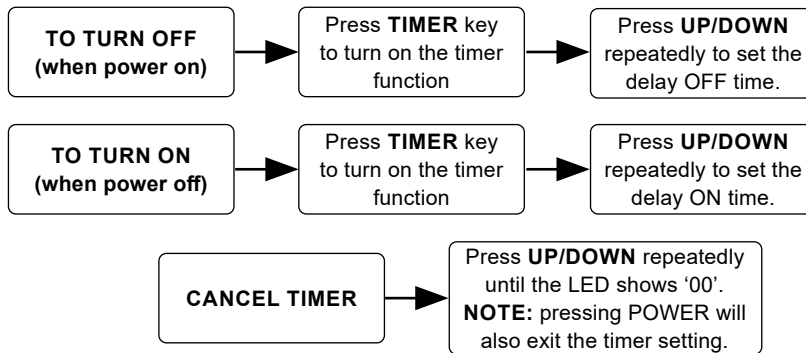

FIG.6

5.9. TIMER SETTINGS

The timer has two ways of operation:



5.10. AUTOMATIC DEFROST

At low room temperatures, frost may build up at the evaporator during operation. The unit will automatically start defrosting and the POWER LED will start blinking. The defrost control sequence is as follows:

- 5.10.1. When the unit operates in the cooling operation, drying operation, the ambient temperature sensor senses the evaporator coil temperature is below -1°C , after the compressor will stop operating for 10 minutes or the coil temperature up to 7°C , the unit restart to cool operating mode.
- 5.10.2. When the unit operates in the heating operation, drying operation, once the coil temperature sensor senses the temperature of the evaporator is below 40°C and the differential temperature between coil temperature and room temperature is below 19°C after the compressor operation for 20 minutes, the unit start defrosting for 5 minutes and the power indicator blinking.

5.11. OVERLOAD PROTECTION

In the event of a power loss, there is a 3 minute delay before the appliance will restart.

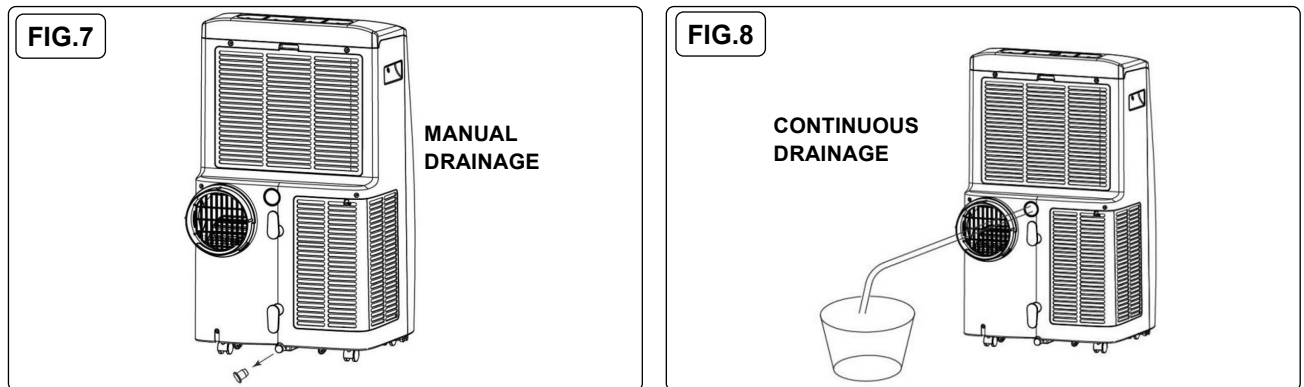

5.12. DRAINAGE

The unit has two methods of drainage. These are manual (fig.7, point 5.13) or continuous (fig.8, point 5.14).

5.13. MANUAL DRAINAGE (FIG.7)

- 5.12.1. Turn off the appliance once the water is full.
- 5.12.2. Unplug the appliance from the power supply.
NOTE: If moving the machine, do it carefully so you do not spill water in the pan at the bottom of the body.
- 5.12.3. Place a container underneath the waste water outlet.
- 5.12.4. Remove the sealing plug and gently title the appliance backwards to aid drainage. Water will flow into the container.
- 5.12.5. Replace the sealing plug.

NOTE: It is recommended to restart the appliance afterwards to reduce condensation running onto the floor.

- × **DO NOT** submerge the end of hose into water; otherwise it can cause "Air Lock" in the hose.

NOTE: TO AVOID WATER SPILLAGE. As the negative pressure of condensate drain pan is large, tilt the drain hose downward toward the floor. It is appropriate that the degree of inclination should exceed 20 degrees. Straighten the hose to avoid a trap existing in the hose.

5.14. CONTINUOUS DRAINAGE (FIG.8)

The self-evaporating system uses the collected water to cool the condenser coils for better efficient performance. It is no need to empty the drainage tank in cooling operation except in drying operation and high humidity conditions. The condensate water evaporates at the condenser and evacuated through the exhaust hose. For continuous operation or unattended operating in drying operation, please connect the attached drain hose to the unit. Condensate water can be automatically flow into a bucket or drain by gravity.

- 5.13.1. Switch off the unit before operating.
- 5.13.2. Remove the plug of the water outlet opening, and keep it in safe area.
- 5.13.3. Securely and properly connect the drain hose and make sure it is not kinked and clear of obstruction.
- 5.13.4. Place the outlet of hose over a drain or bucket and ensure that water could freely flow out of the unit.
- 5.13.5. Do not submerge the end of hose into water; otherwise it can cause "Air Lock" in the hose.
- 5.13.5. To avoid water spillage:

- As the negative pressure of condensate drain pan is large, tilt the drain hose downward toward the floor. It is appropriate that the degree of inclination should exceed 20 degrees.
- Straighten the hose to avoid a trap existing in the hose.

6. MAINTENANCE

6.1. CLEANING THE AIR FILTER (FIG.9)

The air filter is removable for easy cleaning. The filters are situated at the rear of the unit, and are held in place by plastic frames.

× **DO NOT** operate the unit without an air filter, or the evaporator may be contaminated.

6.1.1. Press the POWER button to switch off the unit. Unplug the power cord.

6.1.2. Remove the filter mesh from the unit.

To remove the upper filter: Using the finger grip, pull the top edge gently outwards to release the holding lugs and remove the filter frame.

To remove the lower filter: Undo fixing screw and pull the frame gently outwards to release the holding lugs and remove filter frame.

6.1.3. Use a vacuum cleaner to suck dust from the filter.

6.1.4. Turn the filter over and rinse the air filter under running water. Let the water run through the filter in the opposite direction of air flow.

6.1.5. Set aside and allow the filter to air dry completely before reinstalling.

NOTE: Refitting the filter frames into the machine is the reverse of 6.1.2.

6.2. CLEANING UP OF REFRIGERANT

6.2.1. Gas/vapour heavier than air. May accumulate in confined spaces, particularly at or below ground level.

6.2.2. Eliminate every possible source of ignition.

6.2.3. Use appropriate personal protection equipment (PPE).

6.2.4. Evacuate unnecessary personnel, isolate, and ventilate area.

× **DO NOT** get in eyes, on skin, or on clothing.

× **DO NOT** breathe vapours or gas.

6.2.5. Prevent entry to sewers and public waters.

6.2.6. Stop the source of the release, if safe to do so. Consider the use of water spray to disperse vapours.

6.2.7. Isolate the area until gas has dispersed. Ventilate and gas test area before entering. Contact competent authorities after a spill.

6.3. STORAGE

6.3.1. If you will not be using the unit for an extended period of time (more than a few weeks) it is best to clean the unit and dry it out completely. Please store the unit per the following steps:

6.3.2. Unplug the unit and remove exhaust hose and window kit.

6.3.3. Drain the remaining water from the unit via the drainage stopper (fig.7).

6.3.4. Clean the filter and let it dry completely in a shaded area.

6.3.5. Re-install the filter.

6.3.6. Store the unit in an upright position, in a well-ventilated, dry location.

6.4. FLAMMABLE REFRIGERANTS USED - R290 GAS SAFETY

6.4.1. CHECKS TO THE AREA

Prior to beginning work on systems containing flammable refrigerants, safety checks are necessary to ensure that the risk of ignition is minimised. For repair to the refrigerating system, the following precaution shall be completed prior to conducting work on the system.

6.4.2. WORK PROCEDURE

Work shall be undertaken under a controlled procedure so as to minimise the risk of a flammable gas or vapour being present while the work is being performed.

6.4.3. GENERAL WORK AREA

All maintenance staff and others working in the local area shall be instructed on the nature of work being carried out. Work in confined spaces shall be avoided.

6.4.4. CHECKING FOR PRESENCE OF REFRIGERANT

The area shall be checked with an appropriate refrigerant detector prior to and during work, to ensure the technician is aware of potentially toxic or flammable atmospheres. Ensure that the leak detection equipment being used is suitable for use with all applicable refrigerants, i.e. non-sparking, adequately sealed or intrinsically safe.

6.4.5. PRESENCE OF FIRE EXTINGUISHER

If any hot work is to be conducted on the refrigerating equipment or any associated parts, appropriate fire extinguishing equipment shall be available to hand. Have a dry powder or CO2 fire extinguisher adjacent to the charging area.

6.4.6. NO IGNITION SOURCES

No person carrying out work in relation to a refrigerating system which involves exposing any pipe work shall use any sources of ignition in such a manner that it may lead to the risk of fire or explosion. All possible ignition sources, including cigarette smoking, should be kept sufficiently far away from the site of installation, repairing, removing and disposal, during which refrigerant can possibly be released to the surrounding space. Prior to work taking place, the area around the equipment is to be surveyed to make sure that there are no flammable hazards or ignition risks. "No Smoking" signs shall be displayed.

6.4.7. VENTILATED AREA

Ensure that the area is in the open or that it is adequately ventilated before breaking into the system or conducting any hot work. A degree of ventilation shall continue during the period that the work is carried out. The ventilation should safely disperse any released refrigerant and preferably expel it externally into the atmosphere.

6.4.8. CHECKS TO THE REFRIGERATING EQUIPMENT

Where electrical components are being changed, they shall be fit for the purpose and to the correct specification. At all times, the manufacturer's maintenance and service guidelines shall be followed. If in doubt, consult the manufacturer's technical department for assistance. The following checks shall be applied to installations using flammable refrigerants:

- The actual refrigerant charge is in accordance with the room size within which the refrigerant containing parts are installed.
- The ventilation machinery and outlets are operating adequately and are not obstructed.
- If an indirect refrigerating circuit is being used, the secondary circuit shall be checked for the presence of refrigerant.
- Marking to the equipment continues to be visible and legible. Markings and signs that are illegible shall be corrected.
- Refrigerating pipe or components are installed in a position where they are unlikely to be exposed to any substance which may corrode refrigerant containing components, unless the components are constructed of materials which are inherently resistant to being corroded or are suitably protected against being so corroded.

6.4.9. CHECKS TO ELECTRICAL DEVICES

Repair and maintenance to electrical components shall include initial safety checks and component inspection procedures. If a fault

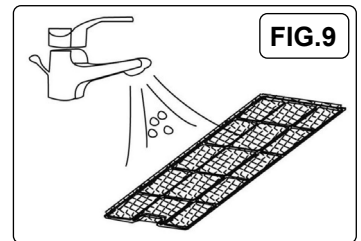

exists that could compromise safety, then no electrical supply shall be connected to the circuit until it is satisfactorily dealt with. If the fault cannot be corrected immediately but it is necessary to continue operation, an adequate temporary solution shall be used. This shall be reported to the owner of the equipment so all parties are advised. Initial safety checks shall include:

- That capacitors are discharged: this shall be done in a safe manner to avoid possibility of sparking.
- That no live electrical components and wiring are exposed while charging, recovering or purging the system.
- That there is continuity of earth bonding.

6.4.10. REPAIRS TO SEALED COMPONENTS

During repairs to sealed components, all electrical supplies shall be disconnected from the equipment being worked upon prior to any removal of sealed covers, etc. If it is absolutely necessary to have an electrical supply to equipment during servicing, then a permanently operating form of leak detection shall be located at the most critical point to warn of a potentially hazardous situation. Particular attention shall be paid to the following to ensure that by working on electrical components, the casing is not altered in such a way that the level of protection is affected. This shall include damage to cables, excessive number of connections, terminals not made to original specification, damage to seals, incorrect fitting of glands, etc. Ensure that the apparatus is mounted securely. Ensure that seals or sealing materials have not degraded to the point that they no longer serve the purpose of preventing the ingress of flammable atmospheres. Replacement parts shall be in accordance with the manufacturer's specifications.

6.4.11. REPAIR TO INTRINSICALLY SAFE COMPONENTS

DO NOT apply any permanent inductive or capacitance loads to the circuit without ensuring that this will not exceed the permissible voltage and current permitted for the equipment in use. Intrinsically safe components are the only types that can be worked on while live in the presence of a flammable atmosphere. The test apparatus shall be at the correct rating. Replace components only with parts specified by the manufacturer. Other parts may result in the ignition of refrigerant in the atmosphere from a leak.

6.4.12. CABLING

Check that cabling will not be subject to wear, corrosion, excessive pressure, vibration, sharp edges or any other adverse environmental effects. The check shall also take into account the effects of aging or continual vibration from sources such as compressors or fans.

6.4.13. DETECTION OF FLAMMABLE REFRIGERANTS

Under no circumstances shall potential sources of ignition be used in the searching for or detection of refrigerant leaks. A halide torch (or any other detector using a naked flame) shall not be used.

Removal and evacuation When breaking into the refrigerant circuit to make repairs – or for any other purpose – conventional procedures shall be used. However, for flammable refrigerants it is important that best practice is followed since flammability is a consideration. The following procedure shall be adhered to:

- Remove refrigerant;
- Purge the circuit with inert gas;
- Evacuate;
- Purge with inert gas;
- Open the circuit by cutting or brazing.

The refrigerant charge shall be recovered into the correct recovery cylinders. For appliances containing flammable refrigerants the system shall be purged with oxygen-free nitrogen to render the appliance safe for flammable refrigerants. This process may need to be repeated several times. Compressed air or oxygen shall not be used for purging refrigerant systems. For appliances containing flammable refrigerant, purging shall be achieved by breaking the vacuum in the system with oxygen-free nitrogen and continuing to fill until the working pressure is achieved, then venting to atmosphere, and finally pulling down to a vacuum. This process shall be repeated until no refrigerant is within the system. When the final oxygen-free nitrogen charge is used, the system shall be vented down to atmospheric pressure to enable work to take place. This operation is absolutely vital if brazing operations on the pipe-work are to take place.

Ensure that the outlet for the vacuum pump is not close to any potential ignition sources and that ventilation is available.

6.4.14. CHARGING PROCEDURES

In addition to conventional charging procedures, the following requirements shall be followed.

- Ensure that contamination of different refrigerants does not occur when using charging equipment. Hoses or lines shall be as short as possible to minimise the amount of refrigerant contained in them.
- Cylinders shall be kept in an appropriate position according to the instructions.
- Ensure that the refrigerating system is earthed prior to charging the system with refrigerant.
- Label the system when charging is complete (if not already).
- Extreme care shall be taken not to overfill the refrigerating system.

Prior to recharging the system, it shall be pressure-tested with the appropriate purging gas. The system shall be leak-tested on completion of charging but prior to commissioning. A follow up leak test shall be carried out prior to leaving the site.

6.4.15. DECOMMISSIONING

Before carrying out this procedure, it is essential that the technician is completely familiar with the equipment and all its detail. It is recommended good practice that all refrigerants are recovered safely. Prior to the task being carried out, an oil and refrigerant sample shall be taken in case analysis is required prior to re-use of recovered refrigerant.

It is essential that electrical power is available before the task is commenced.

A) Become familiar with the equipment and its operation.

B) Isolate system electrically.

C) Before attempting the procedure, ensure that:

- Mechanical handling equipment is available, if required, for handling refrigerant cylinders.
- All personal protective equipment is available and being used correctly.
- The recovery process is supervised at all times by a competent person.
- Recovery equipment and cylinders conform to the appropriate standards.

D) Pump down refrigerant system, if possible.

E) If a vacuum is not possible, make a manifold so that refrigerant can be removed from various parts of the system.

F) Make sure that cylinder is situated on the scales before recovery takes place.

G) Start the recovery machine and operate in accordance with instructions.

H) Do not overfill cylinders (no more than 80 % volume liquid charge).

I) Do not exceed the maximum working pressure of the cylinder, even temporarily.

J) When the cylinders have been filled correctly and the process completed, make sure that the cylinders and the equipment are

removed from site promptly and all isolation valves on the equipment are closed off.

K) Recovered refrigerant shall not be charged into another refrigerating system unless it has been cleaned and checked.

6.4.16. LABELLING

Equipment shall be labelled stating that it has been de-commissioned and emptied of refrigerant. The label shall be dated and signed. For appliances containing flammable refrigerants, ensure that there are labels on the equipment stating the equipment contains flammable refrigerant.

6.4.17. RECOVERY

When removing refrigerant from a system, either for servicing or decommissioning, it is recommended good practice that all refrigerants are removed safely.

When transferring refrigerant into cylinders, ensure that only appropriate refrigerant recovery cylinders are employed. Ensure that the correct number of cylinders for holding the total system charge is available. All cylinders to be used are designated for the recovered refrigerant and labelled for that refrigerant (i.e. special cylinders for the recovery of refrigerant). Cylinders shall be complete with pressure-relief valve and associated shut-off valves in good working order. Empty recovery cylinders are evacuated and, if possible, cooled before recovery occurs.

The recovery equipment shall be in good working order with a set of instructions concerning the equipment that is at hand and shall be suitable for the recovery of all appropriate refrigerants including, when applicable, flammable refrigerants. In addition, a set of calibrated weighing scales shall be available and in good working order. Hoses shall be complete with leak-free disconnect couplings and in good condition. Before using the recovery machine, check that it is in satisfactory working order, has been properly maintained and that any associated electrical components are sealed to prevent ignition in the event of a refrigerant release. Consult manufacturer if in doubt.

The recovered refrigerant shall be returned to the refrigerant supplier in the correct recovery cylinder, and the relevant waste transfer note arranged. Do not mix refrigerants in recovery units and especially not in cylinders.

If compressors or compressor oils are to be removed, ensure that they have been evacuated to an acceptable level to make certain that flammable refrigerant does not remain within the lubricant. The evacuation process shall be carried out prior to returning the compressor to the suppliers.

7. TROUBLESHOOTING

SYMPTOM		INSPECTION	SOLUTION
The unit is not working		Check the mains supply	Insert the power cord securely into the wall outlet
		Check if the water level indicator lights up?	Empty the drain pan. See Section 5.10
		Check the room temperature.	The range of operating temperature is 5-35°C
The unit works with reduced capacity		Check if the air duct is blocked	Clear the obstacle.
		Check the air filter for dirt	Clean the air filter. See Section 7
		Check if the room door or window is open.	Keep the door and windows closed.
		Check if the desired operating mode is selected and temperature is properly set.	Set the mode and temperature at proper set-point See Section 5
		The exhaust hose is detached.	Make sure the exhaust hose is securely attached.
Water Leakage		Overflow while moving the unit.	Empty the water tank before transport.
		Check if the drain hose is kinked or bent.	Straighten the hose to avoid a trap existing.
Excessive Noise		Check if the unit is securely positioned.	Place the unit on horizontal and firm ground.
		Check if any loose, vibrating parts.	Secure and tighten the parts.
		Noise sounds like water flowing.	Noise comes from flowing refrigerant. This is normal.
Error Codes	E0	Communication faults between main PCB and display PCB.	Check the wire harness of the display PCB for damage.
	E1	Ambient temperature sensor failure	Check connection or replace it. To clean or replace the temperature sensor.
	E2	Coil temperature sensor failures.	Check connection or replace it. To clean or replace the temperature sensor.
	Ft	Condensate water high level alarm.	Empty the drain pan. See Section 5.10

WINDOW SEALING KIT FOR AIR CONDITIONER DUCTING

MODEL NO: **SACWK1**

8. SAFETY

- × **DO NOT** cover the unit with this material, and do not obstruct the air inlet and outlet grilles of the machine with items such as clothing, soft furnishings, furniture, bedding etc.
 - × **DO NOT** use the material for any purpose other than that for which it is designed.
 - × **DO NOT** use in bathroom or shower room.
 - × **DO NOT** allow children to use, when not in use, store in a safe, cool, dry, childproof area.
- NOTE:** This material is not intended for use by persons (including children) with reduced physical, sensory or mental capabilities or lack of experience and knowledge, unless they have been given supervision or instruction concerning the use of the appliance by a person responsible for their safety. Children should be supervised to ensure that they do not play with this material.

9. INTRODUCTION

Suitable for all types of hinged windows including skylights up to 300cm total perimeter. Easy to install using the supplied roll of self-adhesive hook & loop tape. Double zip makes positioning the ducting at any height easy. Saves energy by making the air conditioner or dryer more effective.

10. CONTENTS

Window seal
Velcro tape



11. INSTRUCTIONS

11.1. CLEANING

Clean the window and window frame, making them free from grease and dust.

11.2. CUTTING THE VELCRO TAPE TO SIZE

Cut the Velcro tape to size, using a pair of scissors. Mark the middle (M) of the window seal (fig.10). Mark the middle of the window frame and the casement (Fig. 11 to 13) (fig. 11 shows an open window, fig.12 a tilted window and fig.13 an open skylight).

11.3. VELCRO TAPE TO THE WINDOW FRAME

Adhere the Velcro tape to the window frame around the window. Then adhere the Velcro tape fully around the window. Stick the Velcro tape to the front side (in most cases 1 cm wide) of the casement or to the inner surface of the casement (where the window handle is attached).

CAUTION: DO NOT adhere the Velcro tape on the window.

11.4. SEALING WINDOW TO WINDOW FRAME

Adhere the narrow side of the window seal to the Velcro tape on the window frame. Work from the centre and fully adhere the narrow side all the way around. First fasten side A, then side B, starting in the middle and working all the way to the left and right.

IMPORTANT! When fastening, point A must be exactly opposite point B.

11.5. SEALING THE WINDOW

Leave the window ajar and adhere the wide side of the window seal to the Velcro tape of the window.

CAUTION: Leave sufficient space, so that the window seal will not get jammed

11.6. OPENING THE WINDOW SEAL

Open the zip of the window seal approximately 50 cm. Open the zip preferably at the positions marked with "S" and attach the exhaust air hose.

11.7. ATTACHING THE AIR DISCHARGE

Insert the air discharge hose of the air conditioning system through the hole in the window seal and close the zip until the air discharge hose is properly secured

11.8. CLOSING THE WINDOW

If you want to close your window, simply detach the cloth from the Velcro tape. When closing the window take care that the seal is not jammed between the casement and window frame.

NOTE: This window seal ensures that the room remains cool for a longer period of time and keeps insects and mosquitoes out.

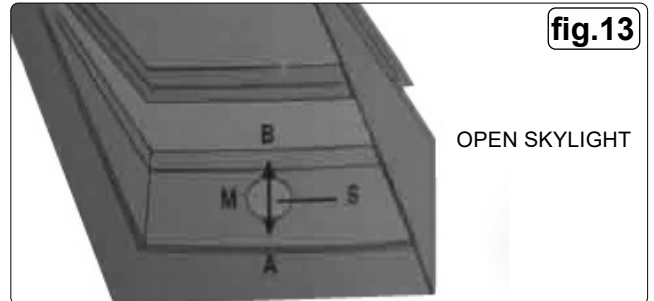
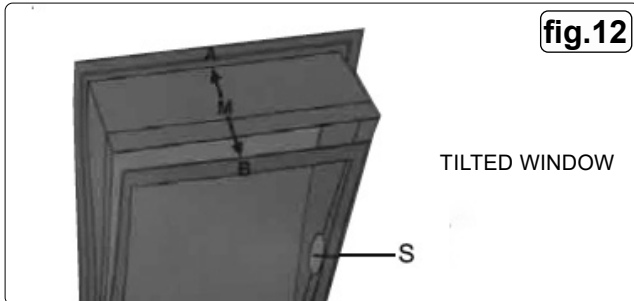
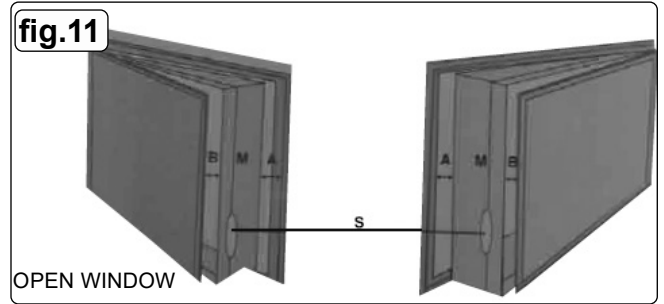
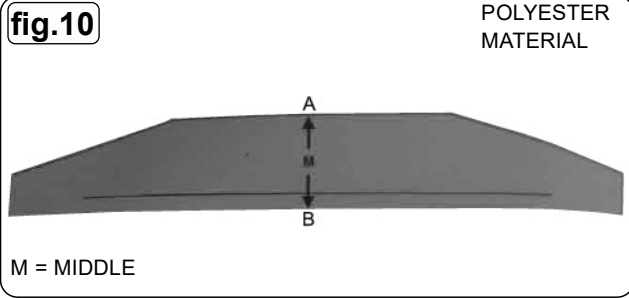

11.9. The installed item resemble fig.14 and fig.15.



ENVIRONMENT PROTECTION

Recycle unwanted materials instead of disposing of them as waste. All tools, accessories and packaging should be sorted, taken to a recycling centre and disposed of in a manner which is compatible with the environment. When the product becomes completely unserviceable and requires disposal, drain any fluids (if applicable) into approved containers and dispose of the product and fluids according to local regulations.



Note: It is our policy to continually improve products and as such we reserve the right to alter data, specifications and component parts without prior notice.

Important: No Liability is accepted for incorrect use of this product.

Warranty: Guarantee is 12 months from purchase date, proof of which is required for any claim.

Sealey Group, Kempson Way, Suffolk Business Park, Bury St Edmunds, Suffolk. IP32 7AR



01284 757500



sales@sealey.co.uk



www.sealey.co.uk

Product Information Sheet. Air Conditioners.

SUPPLIER_NAME_OR_TRADEMARK Sealey EU Ltd.
 DELEGATED_ACT 206/2012/EU
 MODEL_IDENTIFIER SAC16000
 Portable Air Conditioner/Dehumidifier/Air Cooler/Heater with Window Sealing Kit
 16,000Btu/hr
 ADDRESS Farney Street, Carrickmacross, Co. Monaghan, A81 PK68 Ireland
 PHONE_NUMBER 01284 757 500
 EMAIL_ADDRESS TechnicalCompliance@sealey.co.uk

Parameter Verification tolerances

Rated Capacity for cooling kW	4.1
Rated capacity for heating kW	3.2
Power input for cooling kW	1.3
Power input for heating kW	1.3
Rated Energy efficiency ratio	2.6
Rated coefficient of performance	2.4
Power consumption in thermostat-off mode W	
Power consumption in standby mode W	0.5
Electricity consumption of single duct appliances kWh/h Cooling	1.0
Electricity consumption of single duct appliances kWh/h Heating	1.0
Electricity consumption of double duct appliances kWh/a Cooling	NA
Electricity consumption of double duct appliances kWh/a Heating	NA
Sound power level LWA dB	65
Global warming potential GWP kg	3

Suppliers website <https://www.sealey.co.uk/>